

INFORMATION IN THIS DRAWING
PROVIDED FOR REFERENCE ONLY

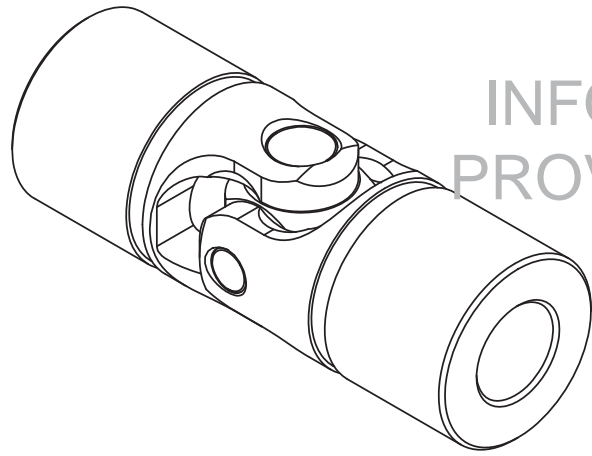

REVISIONS				
ZONE	REV.	DESCRIPTION	DATE	APPROVED

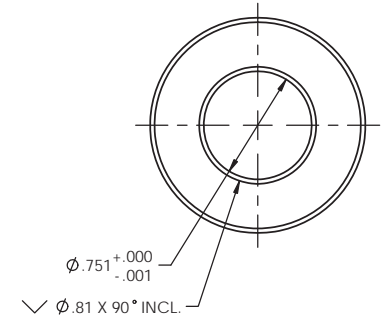
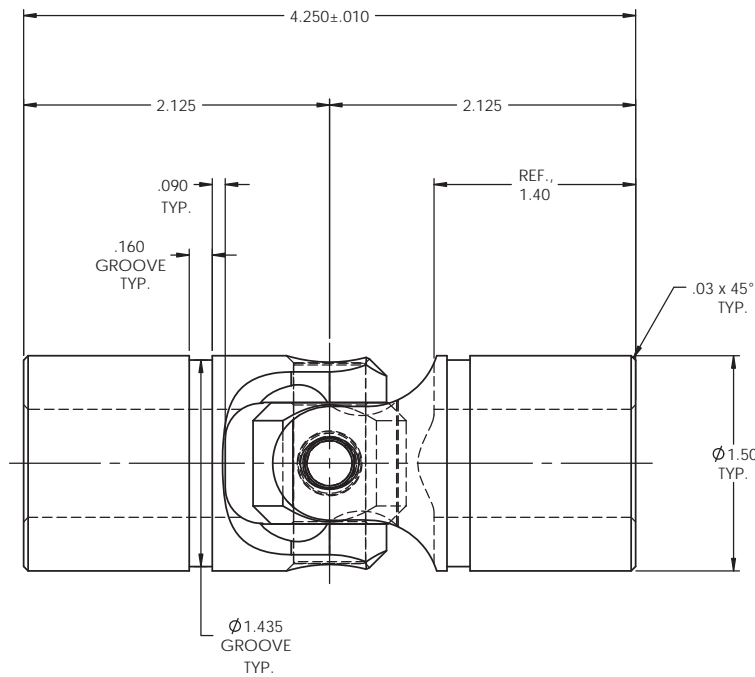
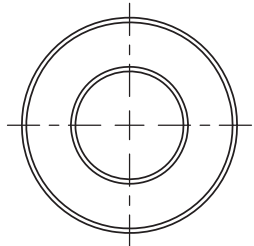

TYPICAL BOTH ENDS

NOTE(S), UNLESS OTHERWISE SPECIFIED.

- (1) UNIVERSAL JOINT IS MARKED w/ "BELDEN" LOGO, PART NUMBER / DRAWING NUMBER, REVISION LEVEL (IF ANY), DATE OF MANUFACTURE (MO/YR), AND BELDEN JOB NUMBER.
- (2) UNIVERSAL JOINT IS LUBRICATED w/ LUBRIPLATE 1200-2, NLGI GRADE 2, AW/EP, LITHIUM GREASE OR EQUIVALENT.
- (3) UNIVERSAL JOINT IS CAPABLE OF OPERATING AT ANY ANGLE UP TO AND INCLUDING 45°.
- (4) UNIVERSAL JOINT HAS STANDARD GROOVES TO ACCEPT INSTALLATION OF PROTECTIVE COVER (BOOT). BOOT AVAILABLE SEPARATELY. REFER TO BELDEN CATALOG, WEBSITE, OR CONTACT BELDEN SALES.
- (5) REFER TO BELDEN CATALOG, WEBSITE, OR CONTACT BELDEN SALES FOR TORQUE CAPACITY.
- (6) THIS DRAWING REPRESENTS A STANDARD BELDEN ITEM. CUSTOM UNIVERSAL JOINTS ARE AVAILABLE UPON REQUEST. PLEASE CONTACT BELDEN SALES.

BELDEN PART NUMBER: UJ-HD1500x750

DO NOT SCALE DRAWING

<small>UNLESS OTHERWISE SPECIFIED CHAMFER ALL HOLES BREAK ALL SHARP CORNERS DE-BURR ALL FEATURES</small>	<small>STANDARD TOLERANCES, UNLESS OTHERWISE SPECIFIED</small> <small>DIMENSIONS ARE IN INCHES [mm]</small> ANGULAR MACHINED: ±1.0° FRACTIONAL: ±.015" TWO PLACE DECIMAL: ±.010" THREE PLACE DECIMAL: ±.005" FOUR PLACE DECIMAL: ±.0005" CONCENTRICITY: .0025" T.I.R.	MATERIAL	ALLOY STEEL	NAME	RNK	DATE	24 JUL 07	Belden Incorporated www.beldenuniversal.com TITLE: ASSEMBLY, UNIVERSAL JOINT				
		DRAWN	RNK	24 JUL 07	CHECKED	RNK	24 JUL 07		SIZE	DWG. NO.	REV	
		HEAT TREAT	SEE DETAIL DRAWINGS	ENG APPR.	RNK	24 JUL 07	MFG APPR.			C	UJ-HD1500x750	
		MILLED SURFACES:	125	FINISH	SEE NOTE(S)	COMMENTS:				SCALE: 3:2	WT (Lbs): 1.464	SHEET 1 OF 2
<small>PROPRIETARY AND CONFIDENTIAL</small> <small>THE INFORMATION CONTAINED IN THIS DRAWING IS THE SOLE PROPERTY OF BELDEN INCORPORATED. ANY REPRODUCTION IN PART OR AS A WHOLE WITHOUT THE WRITTEN PERMISSION OF BELDEN INCORPORATED IS PROHIBITED.</small>	<small>ALL HOLES TO BE LOCATED ON CENTERLINE (C) WITHIN .005" T.I.R.</small> <small>INTERPRET GEOMETRIC TOLERANCES I.A.W. ANSI Y14.5M-1992</small>											