

APPROVED

FOR REFERENCE ONLY

REVISIONS				
ZONE	REV.	DESCRIPTION	DATE	APPROVED
	A	INITIAL RELEASE	5/31/2019	JP

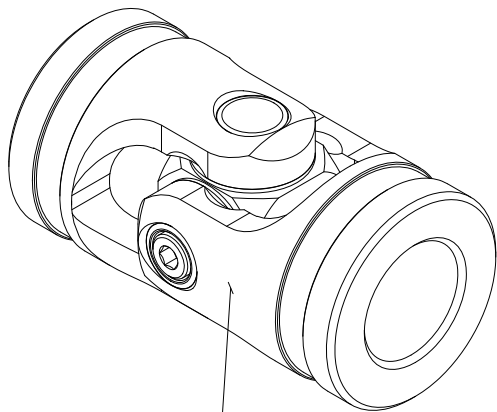

1

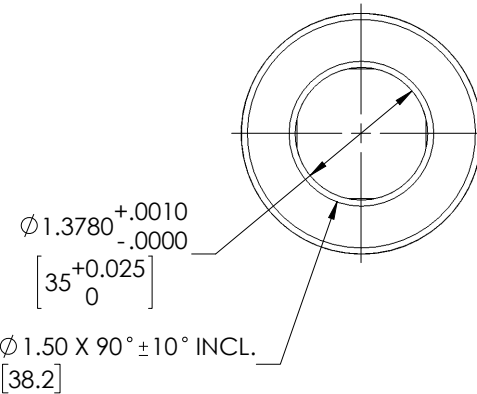
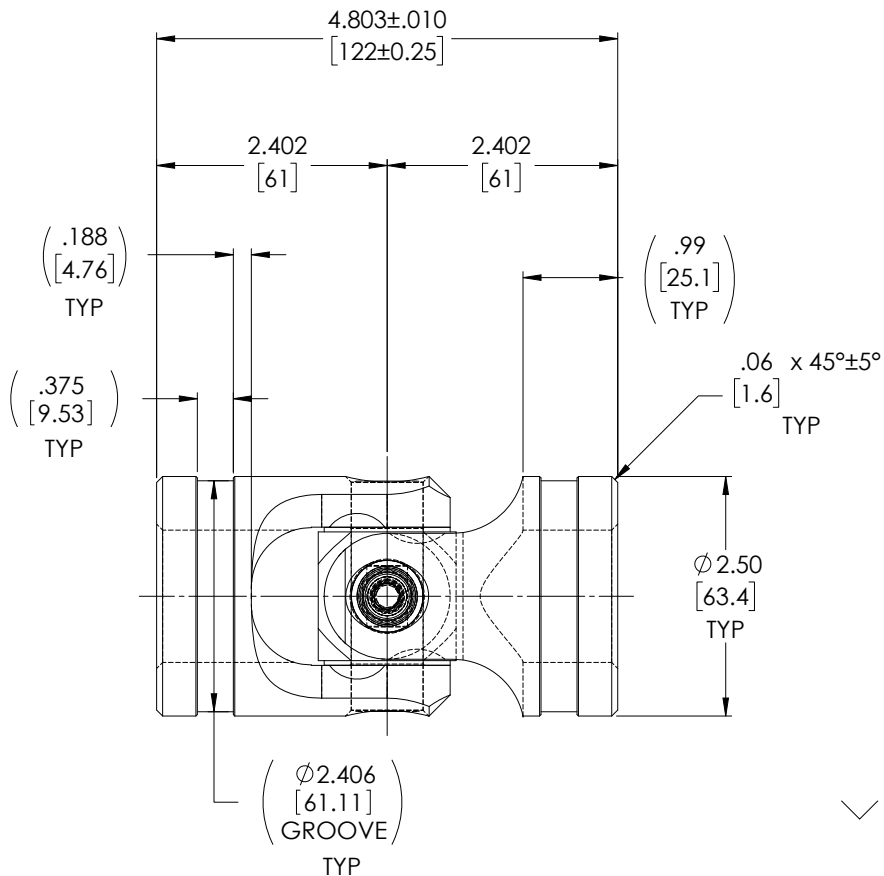
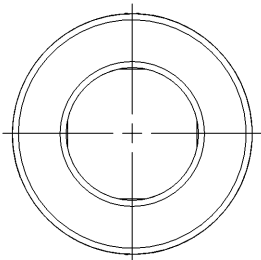

TYPICAL BOTH ENDS

NOTE(s), UNLESS OTHERWISE SPECIFIED.

1 MARK ASSEMBLY w/ "BELDEN" LOGO, PART NUMBER, REVISION LEVEL (IF ANY), DATE OF MANUFACTURE, & BELDEN JOB NUMBER.

(2) LUBRICATE w/ LUBRIPLATE PRODUCT No. 1200-2, NLGI GRADE 2, AW/EP, LITHIUM GREASE OR EQUIVALENT.

(3) TORQUE M8x1.25 SOCKET HEAD CAP SCREW TO 20 FT-LBS.

(4) REF., MAXIMUM OPERATION ANGLE: 45°.

DO NOT SCALE DRAWING

UNLESS OTHERWISE SPECIFIED CHAMFER ALL HOLES BREAK ALL SHARP CORNERS DE-BURR ALL FEATURES TURNED SURFACES: $\sqrt{63}$ MILLED SURFACES: $\sqrt{125}$ PROPRIETARY AND CONFIDENTIAL THE INFORMATION CONTAINED IN THIS DRAWING IS THE SOLE PROPERTY OF BELDEN UNIVERSAL. ANY REPRODUCTION IN PART OR AS A WHOLE WITHOUT THE WRITTEN PERMISSION OF BELDEN UNIVERSAL IS PROHIBITED.	STANDARD TOLERANCES, UNLESS OTHERWISE SPECIFIED DIMENSIONS ARE IN INCHES [mm] ANGULAR MACHINED: $\pm 1.0^\circ$ FRACTIONAL: $\pm .015$ TWO PLACE DECIMAL: $\pm .010$ THREE PLACE DECIMAL: $\pm .005$ FOUR PLACE DECIMAL: $\pm .0005$ CONCENTRICITY: $.0025$ T.I.R.	MATERIAL: ALLOY STEEL HEAT TREAT: SEE DETAILS FINISH: NONE	INITIALS: JP DATE: 31MAY19 CHECKED: RNK DATE: 06/24/2019 ENG APPR: RNK DATE: 07/22/2019 MFG APPR: QC APPR: COMMENTS:	Belden Incorporated www.beldenuniversal.com TITLE: ASSEMBLY, UNIVERSAL JOINT
	ALL HOLES TO BE LOCATED ON CENTERLINE (C) WITHIN .005" T.I.R. INTERPRET GEOMETRIC TOLERANCES I.A.W. ASME Y14.5	SIZE: A DWG. NO.: UJ-HD2500x35-122 SCALE: 1:1 WT (Lbs): 4.001 SHEET 1 OF 2	REV: A	