

# APPROVED

## FOR REFERENCE ONLY

REVISIONS				
ZONE	REV.	DESCRIPTION	DATE	APPROVED
	A	INITIAL RELEASE	6/3/2019	JP

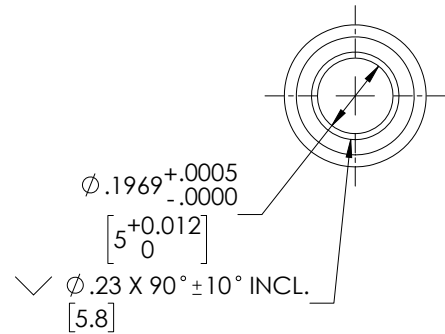
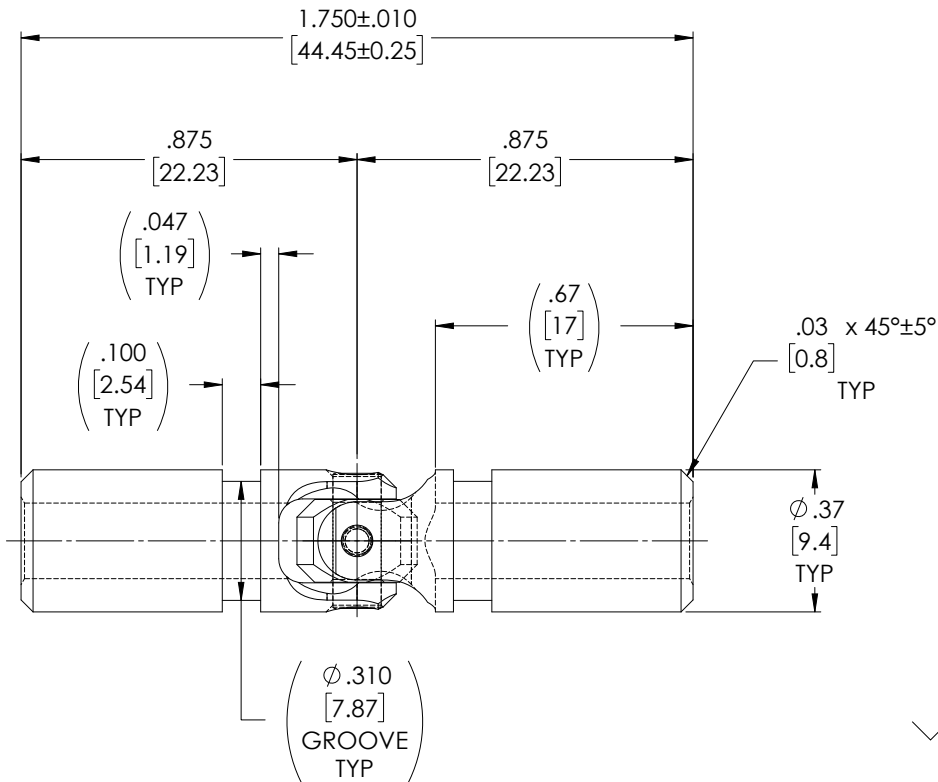
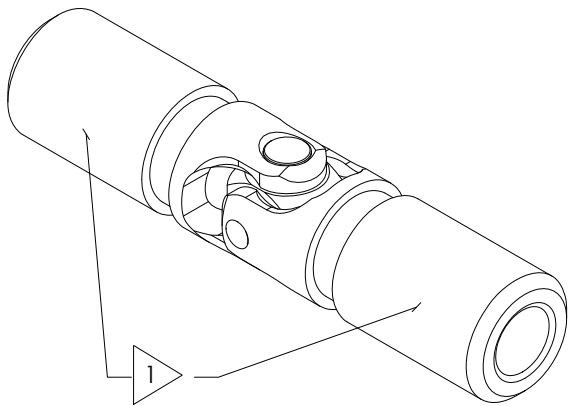

TYPICAL BOTH ENDS

NOTE(s), UNLESS OTHERWISE SPECIFIED.

- 1 MARK ASSEMBLY w/ "BELDEN" & BELDEN JOB No.
- (2) LUBRICATE U-JOINT w/ LUBRIPLATE # 1200-2, NLGI GRADE 2, AW/EP, LITHIUM GREASE OR EQUIVALENT.
- (3) REFERENCE, MATERIAL: YOKES... TYPE 303 STAINLESS STEEL, BLOCK & PINS... TYPE 416 STAINLESS STEEL.
- (4) REF., MAXIMUM OPERATING ANGLE:  $45^\circ$

DO NOT SCALE DRAWING

<small>UNLESS OTHERWISE SPECIFIED CHAMFER ALL HOLES BREAK ALL SHARP CORNERS DE-BURR ALL FEATURES</small>	<small>STANDARD TOLERANCES, UNLESS OTHERWISE SPECIFIED</small>  <small>DIMENSIONS ARE IN INCHES [mm]</small> ANGULAR MACHINED: $\pm 1.0^\circ$ FRACTIONAL: $\pm .015$ TWO PLACE DECIMAL: $\pm .010$ THREE PLACE DECIMAL: $\pm .005$ FOUR PLACE DECIMAL: $\pm .0005$ CONCENTRICITY: $.0025$ T.I.R.	MATERIAL <b>STAINLESS STEEL</b>	INITIALS	DATE	<b>Belden Incorporated</b> <a href="http://www.beldenuniversal.com">www.beldenuniversal.com</a>  TITLE: <b>ASSEMBLY, UNIVERSAL JOINT</b>	
			DRAWN	JP		03JUN19
			CHECKED	RNK		06/24/2019
			ENG APPR.	RNK		07/12/2019
<small>TURNED SURFACES: <math>\sqrt{63}</math> MILLED SURFACES: <math>\sqrt{125}</math></small>	<small>FINISH</small> NONE	<small>HEAT TREAT</small> SEE DETAIL DRAWINGS	<small>COMMENTS:</small>		<small>SIZE</small> <b>A</b>	
<small>PROPRIETARY AND CONFIDENTIAL</small> <small>THE INFORMATION CONTAINED IN THIS DRAWING IS THE SOLE PROPERTY OF BELDEN UNIVERSAL. ANY REPRODUCTION IN PART OR AS A WHOLE WITHOUT THE WRITTEN PERMISSION OF BELDEN UNIVERSAL IS PROHIBITED.</small>	<small>ALL HOLES TO BE LOCATED ON CENTERLINE (C) WITHIN .005" T.I.R.</small> <small>INTERPRET GEOMETRIC TOLERANCES I.A.W. ASME Y14.5</small>	<small>MFG APPR.</small> <small>QC APPR.</small>	<small>SCALE: 4:1</small>	<small>WT (Lbs): 0.036</small>	<small>SHEET 1 OF 2</small>	